



V-RAD
Vacuum-Revolving Automatic Doser

Operation and Maintenance Manual

V-RAD

Vacuum-Revolving Automatic Doser

Operation & Maintenance Manual

Table of Contents

I. Installation.....	3
Operation.....	3
II. Maintenance.....	5
III. Troubleshooting	6
Flow Charts and Drawings	
Figure 1 System Diagram.....	4
Figure 2 Circuit Board Drawing.....	7
Figure 3 Valve Body Drawing.....	8
Figure 4 Motor Assembly Drawing.....	9

RIGHT TO REVISE: Hydro Instruments reserves the right to make engineering revisions and improvements at any time. Please contact Hydro Instruments if there is any discrepancy between the literature and the product provided.

I. INSTALLATION OF THE V-RAD

NOTE: The V-RAD is designed for use in vacuum feed systems only.

MECHANICAL: Install the V-RAD in the vacuum line between the ejector and the chemical storage container (see Figure 1). Vacuum tubing and connectors are provided.

ELECTRICAL: The V-RAD is provided with a standard 6-foot power cord, which can be removed if hard wiring is desired. An operation (enable/disable) relay input is provided (see Figure 2) for applications where intermittent operation is needed. This circuit board connection is labeled R1- and R1+. The R1+ and R1- connection accepts a 24 Volt signal from an external relay. When using this feature, the V-RAD will operate normally until the 24 Volt input changes at which time it will pause in the next “No Feed” position. Options are:

- A. Normally Cold:** In this mode, the V-RAD will behave normally when the 24 Volt is absent. When 24 Volts are supplied to the R1 input the unit will pause in the next “No Feed” position. Any new V-RAD is in this mode.
- B. Normally Hot:** In this mode, the V-RAD will behave normally when the 24 Volt is present. When 24 Volts are interrupted to the R1 input the unit will pause in the next “No Feed” position. To place the V-RAD in this mode:
 1. Secure power to the V-RAD.
 2. Hold the Plus Button while re-supplying power.

Note: To return to the Normally Cold mode, perform the same steps except hold the Minus Button when re-supplying power.

Operation

GENERAL: The V-RAD operates by opening and closing a fixed orifice valve. Each movement of the valve is followed by a pause. The chemical feed rate is set by controlling the ratio between duration of pause in the open position and duration of pause in the closed position.

MANUAL: In manual mode, the feed rate is adjusted by entering the desired feed rate with the plus and minus pushbuttons.

AUTOMATIC: After connecting the 4-20 mA input signal to the circuit board next to the label “FLO/GND”, the V-RAD is placed in automatic mode by pressing the button labeled “Auto/Man” until the LED labeled “A” is lit. The unit will now adjust the feed rate in proportion to the incoming signal. A dosage adjustment is provided via the plus and minus pushbuttons. If the 4-20 mA input signal is lost for any reason, the V-RAD will move to the next closed position and remain there and the display will show “OFF”.

Note: During operation the valve seat will wear. This will result in some chemical feeding around the valve stem when the valve is paused in the closed position. This may require the feed setting to be periodically reduced over time to compensate for the slight increase in the feed capacity of the unit.

PAUSE: For convenience, a pause button is provided to stop the valve in a given position.

PERIOD: The V-RAD includes an adjustable period potentiometer (on the circuit board). This potentiometer allows the user to adjust the total time of any two adjacent pauses. It is adjustable from 5 to 60 seconds and factory set (and recommended) at 15 seconds. Reducing this period will increase the rate of wear and reduce the useful life of internal parts. Increasing the period will reduce the smoothness of the chemical injection.

CALIBRATING/CHANGING THE FULL SCALE: To recalibrate the V-RAD's full scale setting, set the feed rate (in Manual mode) to the current max feed rate and observe the feed rate using a calibration column. Calibration columns are available from Hydro Instruments. If the feed rate observed on the calibration column is different than the displayed setting, adjust the full scale as follows:

1. Adjust the feed rate down to any setting below full scale. This will avoid confusion when entering the full scale adjustment screen.
2. Press and hold the "Auto/Man" pushbutton.
3. Press and release the "Pause" pushbutton.
4. Release the "Auto/Man" pushbutton.
5. Adjust the full scale setting using the "+" and "-" pushbuttons.

Note: After 10 seconds without adjustments, the screen will return to normal operation.

FIGURE 1

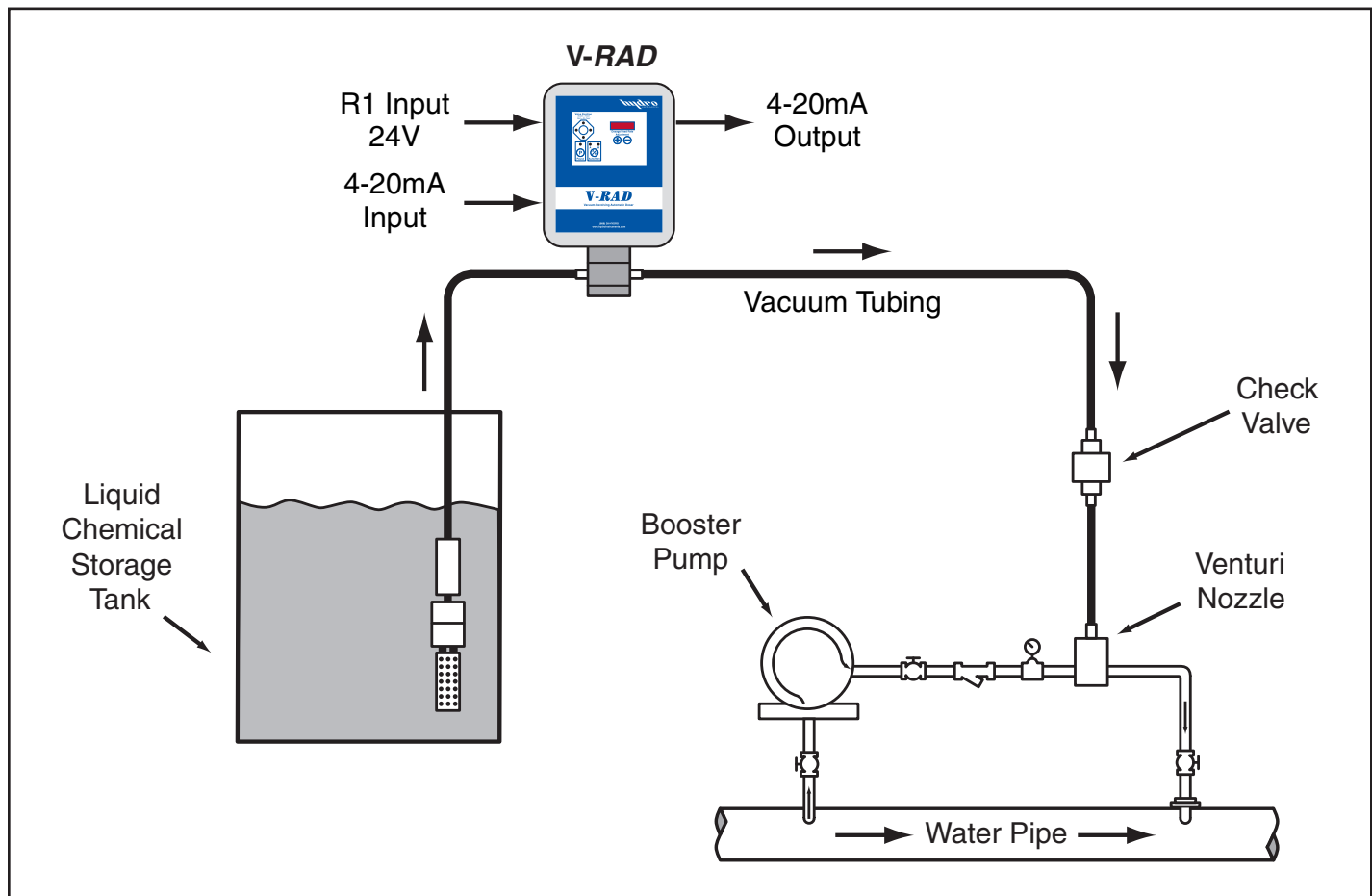

II. MAINTENANCE

Recommended schedule:

Valve Seat	6 months (or when needed to reduce valve leak-by)
Shaft Seal	Annually
O-Rings and Body Gasket	24 months

Disassembly of the valve portion (see Figure 3):

1. Disconnect the V-RAD from the electrical power source prior to attempting any maintenance.
2. Unscrew the four bolts on the bottom of the V-RAD valve portion and remove the PVC Body Cap and bolts.
3. Slide the Middle Body off of the Valve Stem. It may be necessary to hold the Window Disc and wiggle the middle body side-to-side while pulling it off of the stem.
4. Open the door on the V-RAD enclosure and remove the cotter pin connecting the Valve Shaft to the Window Disc.
5. Remove the shaft.
6. Using a $\frac{5}{32}$ " Allen wrench, unscrew the four bolts connecting the Upper Body to the enclosure. The Upper Body should be removed carefully so as not to drop the small bearing parts.
7. Once the Upper Body is removed, the Disc, Bearing, Bushing and Shaft Seal can be removed.

Rebuilding the valve (see Figure 3):

1. After cleaning the Upper Body thoroughly, install the shaft. Carefully slide the Seal, Bushing, Bearing and Disc over the shaft. Use a new Body Gasket and reconnect the Upper Body to the enclosure using the four Allen-head bolts.
2. Reconnect the shaft to the Window Disc using a $\frac{3}{16}$ " stainless steel cotter pin. (If it was necessary to replace the Valve Stem you must do so before reconnecting the Valve Stem to the Window Disc.)
3. Ensure the Valve Stem is clean and replace the white (Teflon) Valve Seat in the Middle Body. This part can generally be pressed in and out by hand or if necessary by gently tapping with a mallet. It is important to install the Valve Seat with the small relief ports facing down (towards the Body Cap).
4. Replace the 3RS-124 O-Ring on the Middle Body.
5. Making sure the expansion ports in the seat face down (away from the enclosure) slide the Middle Body over the Valve Stem.
6. Replace the 3RS-124 O-Ring on the Body Cap and reassemble using the four body bolts.

NOTE: After refurbishing the V-RAD valve portion using a new seat, it may be necessary to help the motor drive the valve for a few initial turns. This is accomplished by turning the Window Disc with your thumb when the motor is attempting to move the valve.

III. TROUBLESHOOTING

Chemical feed rate is too high.

1. Lower the feed setting (if in manual) or the dosage (if in automatic).
2. Replace the valve seat.

Chemical feed rate or residual level is too low.

1. Raise the feed rate setting or dosage adjustment.
2. Verify chemical storage container is not empty and that the suction strainer is clean and completely submerged.
3. Disconnect vacuum tubing from the ejector and verify the ejector is pulling sufficient vacuum.
4. Inspect all vacuum tubing, piping and connections for breaks or leaks. Conduct a vacuum test using a vacuum gauge if necessary.
5. Inspect the ejector and/or chemical injection point for scale build-up or restrictions. Clean if necessary.
6. Remove the Body Cap and Middle Body to expose the stem. Check for any debris or build-up that may be restricting the orifice. Clean if necessary. Replace the Stem if needed.

Motor does not turn.

1. Verify that the “Pause” LED indicator is not illuminated. Verify that the “Pause” button is operating properly pressing until the LED illuminated and pressing it again until the LED is extinguished.
2. If the V-RAD is being operated automatically using a 4-20mA input signal, the input signal may have been lost. This would be further indicated if the unit is in a “No Feed” position (with a red LED indicator illuminated). Check the signal wiring into the V-RAD. If the connection appears good, disconnect the wiring and test the signal.

V-RAD display and LED's will not illuminate.

1. Verify that the power source is available (breakers, fuses, relays etc.).
2. Inspect the power connections to the V-RAD circuit board.
3. After following step one and two, try restarting by removing and re-supplying power to the V-RAD.

Residual Tests Show Fluctuating Level.

1. Although the residual level may fluctuate slightly at a nearby sample point, this effect will be evened out further downstream. If the fluctuation is determined to be unsatisfactory, reduce the Period Adjustment.

NOTE: Reducing the Period Adjustment will result in an accelerated wear rate of the Valve Seat.

FIGURE 2

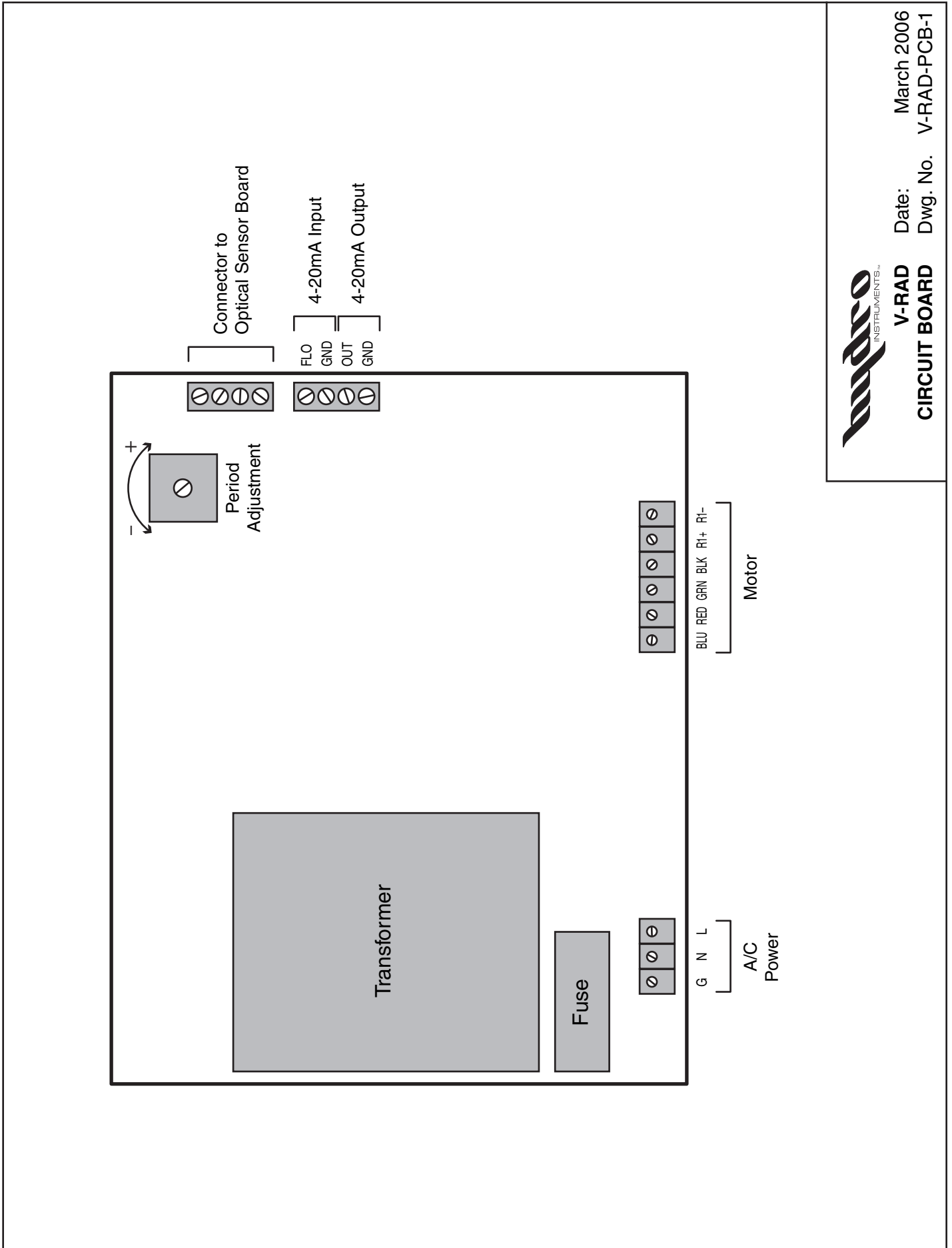

V-RAD
CIRCUIT BOARD

Date: March 2006
Dwg. No. V-RAD-PCB-1

FIGURE 3

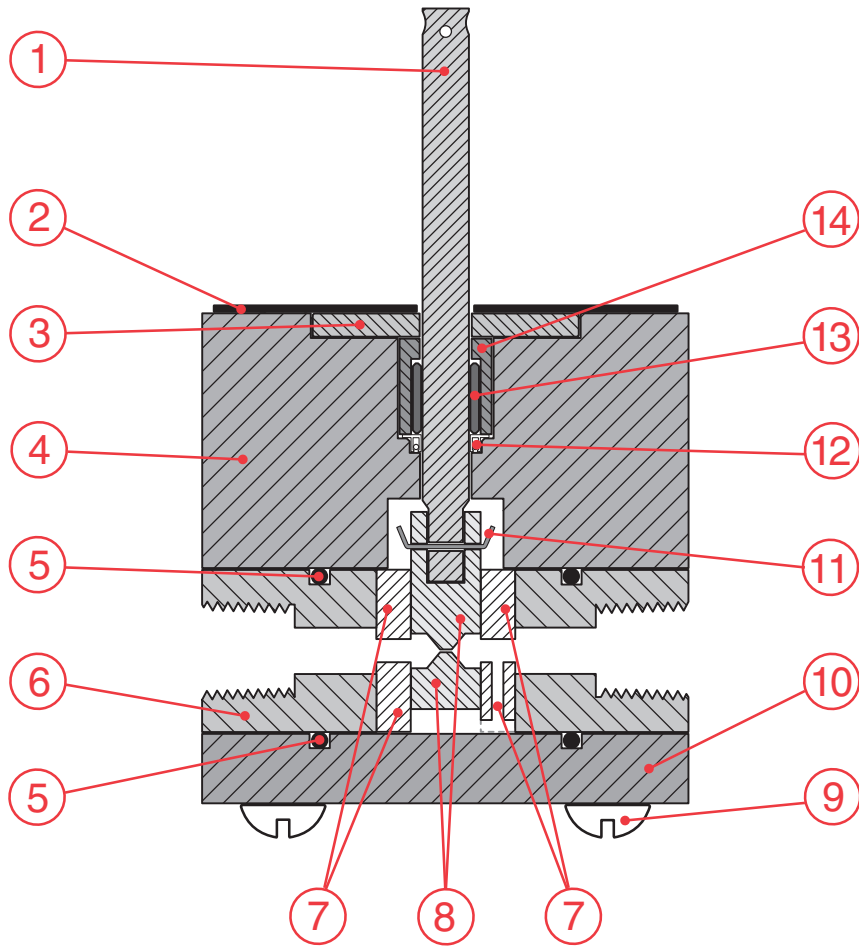

Item No.	Description	Quantity	Part No.	Item No.	Description	Quantity	Part No.
1	Shaft	1	LS-1	8	Valve Stem	1	LVST-1
2	Gasket	1	LGA-1	9	Bolts	4	1/4"-20 x 1 1/2"
3	Large Disk	1	AV-3	10	Body Cap	1	LBC-1
4	Upper Body	1	LUB-1	11	Pin	1	---
5	O-Ring	2	3RS-124	12	Seal	1	LSE-1
6	Middle Body	1	LMB-1	13	Bearing	1	LBE-1
7	Valve Seat	1	LVS-1	14	Seal Bushing	1	LSB-1
				 Date: March 2006 Scale: 100% Dwg. No. V-RAD			

FIGURE 4



hydro
INSTRUMENTS™

V-RAD
FEATURING MOTOR ASSEMBLY

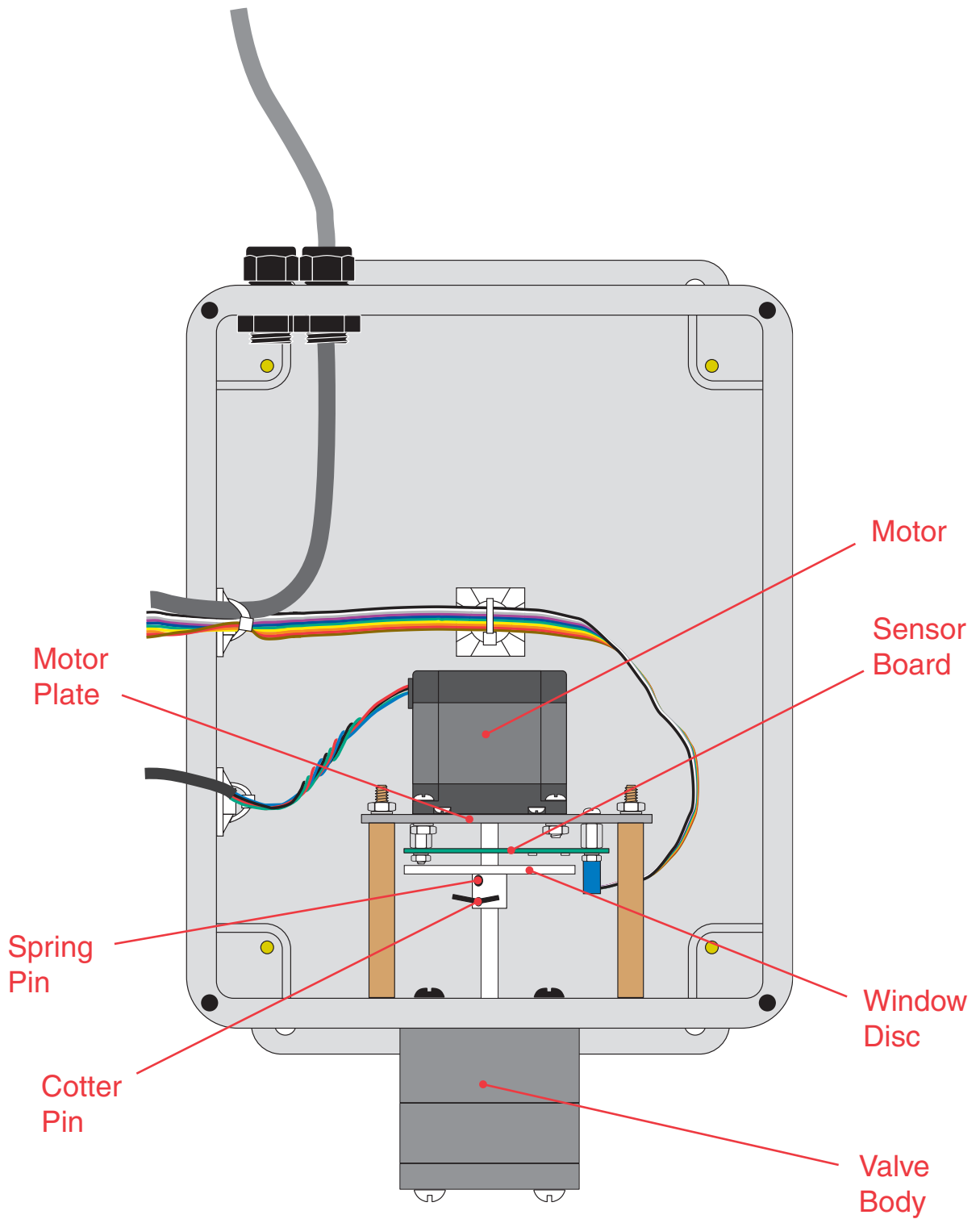
Date: March 2006

Scale: 45%

Dwg. No.: V-RAD-MA