



Remote Meters with 4-20 Output Instruction and Operation Manual

The information contained in this manual was current at the time of printing. The most current versions of all Hydro Instruments manuals can be found on our website: www.hydroinstruments.com

Series RM Rev. 8/4/2025

Remote Meters with 4-20 Output Instruction and Operation Manual

Table of Contents

I. Safety Precautions	3
II. Theory of Operation	3
III. Specifications	3
IV. Installation	4
V. Maintenance.....	4
VI. Troubleshooting	5
Parts Drawings.....	6-11
Wiring Diagram	10

I. SAFETY PRECAUTIONS

GENERAL: Be sure to follow all applicable and prudent safety precautions when working with chemical and electrical equipment.

ELECTRICAL: The circuit board and incoming A/C power line do include electrical shock risk. Take care to avoid electrical shocks and do not touch any part of the circuit board or A/C power line unless you are certain that A/C power has been disconnected from the system.

CHECK FOR DAMAGE: Before removing the product from the shipping packaging, carefully check the equipment for damage. If any product is found damaged, do not put it into operation or install it. Contact Hydro Instruments to discuss repair or replacement of the damaged sensor.

II. THEORY OF OPERATION

These remote meters work like a variable area flow meter, but with a slight twist. As with most variable area flow meters, as flow is increased/decreased it applies a certain amount of force to the float moving it up/down the tube, thus changing the surface area between the float and the glass wall until enough flow can go around the float and an equilibrium level is reached. The flow rate can then be determined based on calibrated markings on the tube. Hydro Instruments has taken this technology one step further by incorporating the use of magnetic fields. Implanted in the float is a magnet and behind the flow tube is a circuit board with Hall Effect sensors spaced out to the graduations on the tube. Thus as the magnet passes these sensors, a current is generated based on the float position which allows for remote monitoring of the flow rate.

III. SPECIFICATIONS

Gas Type:	Chlorine and Sulfur Dioxide
Power requirements:	12-24 VDC
Outputs:	(1) 4-20 mA output
Accuracy:	5% of full scale
Connections:	100 - 500 PPD (2 - 10 Kg/h) – ½" FPT ports on the rear and side. 1,000 - 3,000 PPD (20 - 60 Kg/h) – 1" NPT Sch.80 PVC unions. 4,000 - 10,000 PPD (80 - 160 Kg/h) – 1.5" Sch.80 PVC unions.

All meters have a ¼" FPT (6.5mm) port for connecting a vacuum gauge and/or differential pressure regulator.

IV. INSTALLATION

1. Find a suitable location to mount the remote meter to a wall, panel or appropriate fixture. Four mounting holes are provided in the meter back panel.
2. Connect the red wire coming from the circuit board to the V+ terminal on a 12 to 24 VDC power supply board.
3. Connect the black wire coming from the circuit board to the V- terminal on the power supply board.
4. Connect the green wire coming from the circuit board to the positive terminal on the 4-20 mA receiver
5. Connect the white wire coming from the circuit board to the common/ground on the 4-20 mA receiver.
6. Install inlet and outlet chemical piping.

NOTE: Should the connector and cable included with the unit become broken or damaged or the operator has chosen not to use it, the four pin terminals on the circuit board (from left to right) correspond to V+, V-, AO+, AO-. (See diagram, page 11.)

V. MAINTENANCE

Remote meters should be serviced at least once a year or sooner based on site conditions. Hydro Instruments provides parts and maintenance kits to ensure that the appropriate materials are used. Please reference the appropriate parts drawing when installing maintenance parts.

1. Using appropriate procedures evacuate all chemical from the feed line and isolate the remote meter from the system.
2. Unscrew the inlet plug and remove the flow tube and float.
3. Inspect and replace all gaskets and O-rings. Refer to the appropriate parts and maintenance kit and parts drawing for appropriate items and their locations.
4. Using warm water only, clean and rinse the flow meter tube and float.
5. Dry and re-install flow meter tube and float.

VI. TROUBLESHOOTING

Problem	Probable Cause	Corrective Actions
No mA output	Improper wiring	Check wiring
	Power supply disconnected	Check wiring & Molex connector on circuit board
	Float/circuit board damage	Inspect float and circuit board, replace if necessary
No chemical feed	Rate valve closed	Rotate rate valve knob to ensure open
	Vacuum leak	Check and correct leaks
	Ejector	Ejector Ensure ejector is creating vacuum

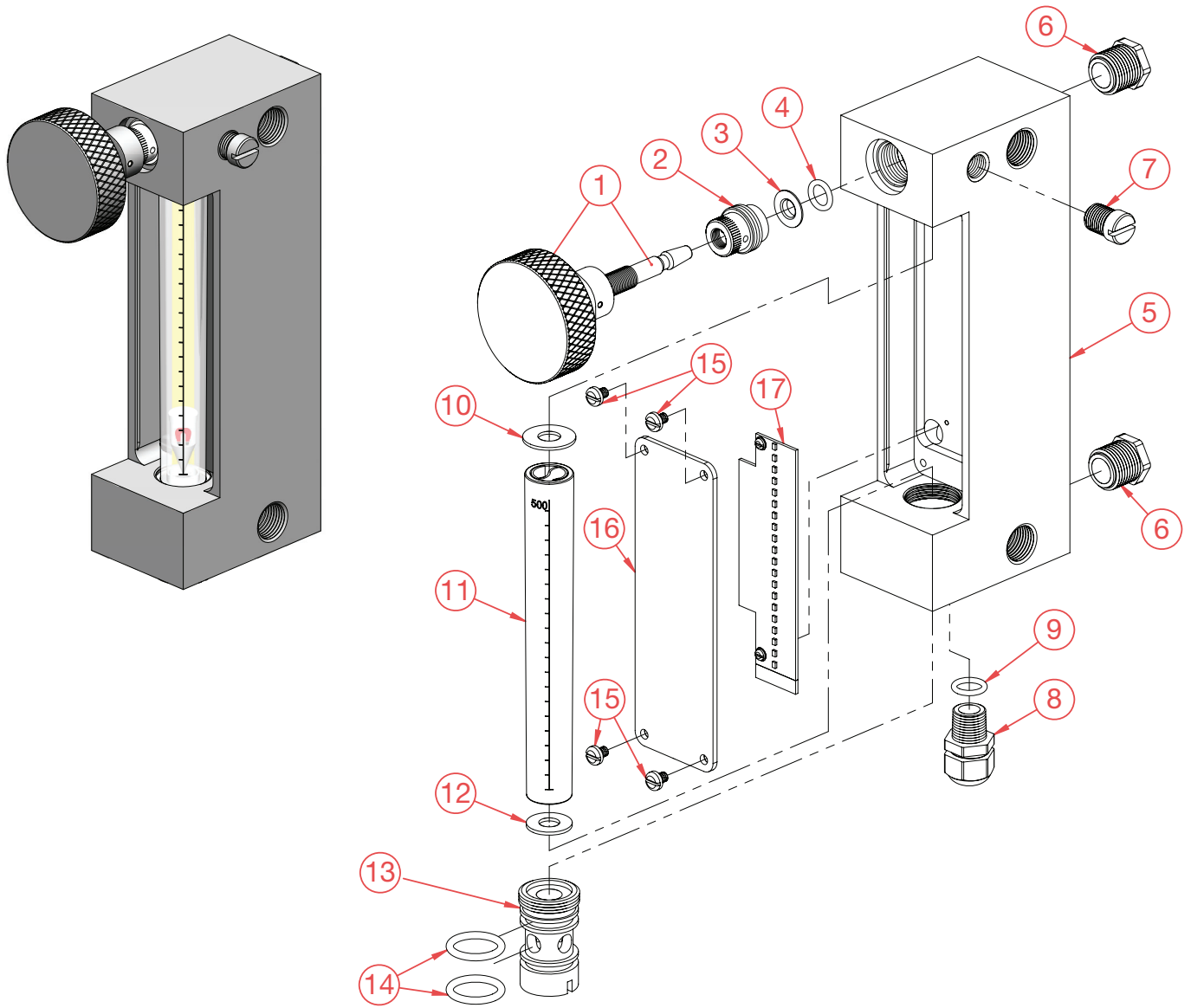

XXX =	100
	250
	500



 Date: 2025-08-04-v3
EXPLODED VIEW
 6" CABINET MOUNTED REMOTE METER w/ Analog Output 4-20mA
 Dwg. No. RMH-XXX-CL2-420MA

Item No.	Description	Quantity	Part No.	Item No.	Description	Quantity	Part No.
1	Rate Valve Stem & Large Knob	1	S-495-CAB-500	12	^{PM} Bottom Meter Gasket	1	G-162
2	Rate Valve Bonnet	1	S-493	13	Meter Inlet	1	MIH-232-500
3	^{PM} Shaft Seal (Teflon)	1	SA-498	14	^{PM} O-Ring	2	OH-VIT-212
4	^{PM} O-Ring	1	OH-VIT-111	15	Screw	4	10-24 x 1/4"
5	Meter Panel Body (4-20mA)	1	MPH-261-420-1	16	Circuit Board Cover	1	MPH-500-CBC
6	1/2" NPT Plug	2	850-005	17	Sensor Board	1	
7	1/4" NPT Plug	1	PLH-108-250	*	Float with magnet (100 PPD / 2 Kg/h)	1	MTH-420-100-FL
8	Liquid Tight Fitting	1	BLT-199	*	Float with magnet (250 PPD / 5 Kg/h)	1	MTH-420-250-FL
9	Required O-Ring for Liquid Tight Fitting	1	OH-VIT-112	*	Float with magnet (500 PPD / 10 Kg/h)	1	MTH-420-500-FL
10	^{PM} Top Meter Gasket	1	G-161	*	Not shown. Float located inside meter tube.		
11	6" Meter Tube with Magnet Float (100 PPD / 2 Kg/h)	1	MTH-420-100	^{PM}	Part & Maintenance Kit		KT5-702-RMP
11	6" Meter Tube with Magent Float (250 PPD / 5 Kg/h)	1	MTH-420-250				
11	6" Meter Tube with Magnet Float (500 PPD / 10 Kg/h)	1	MTH-420-500				

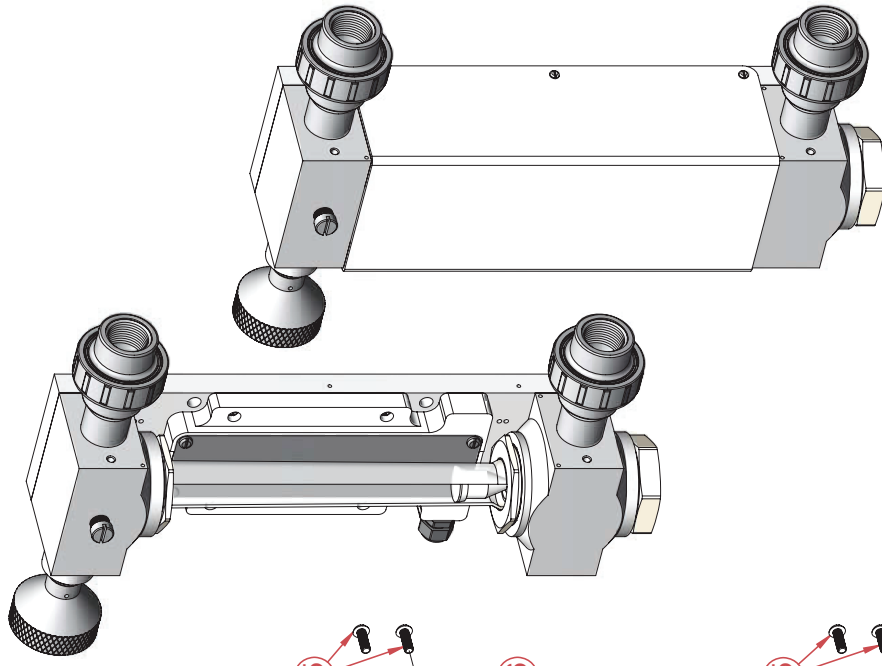
	100
XXX =	250
	500

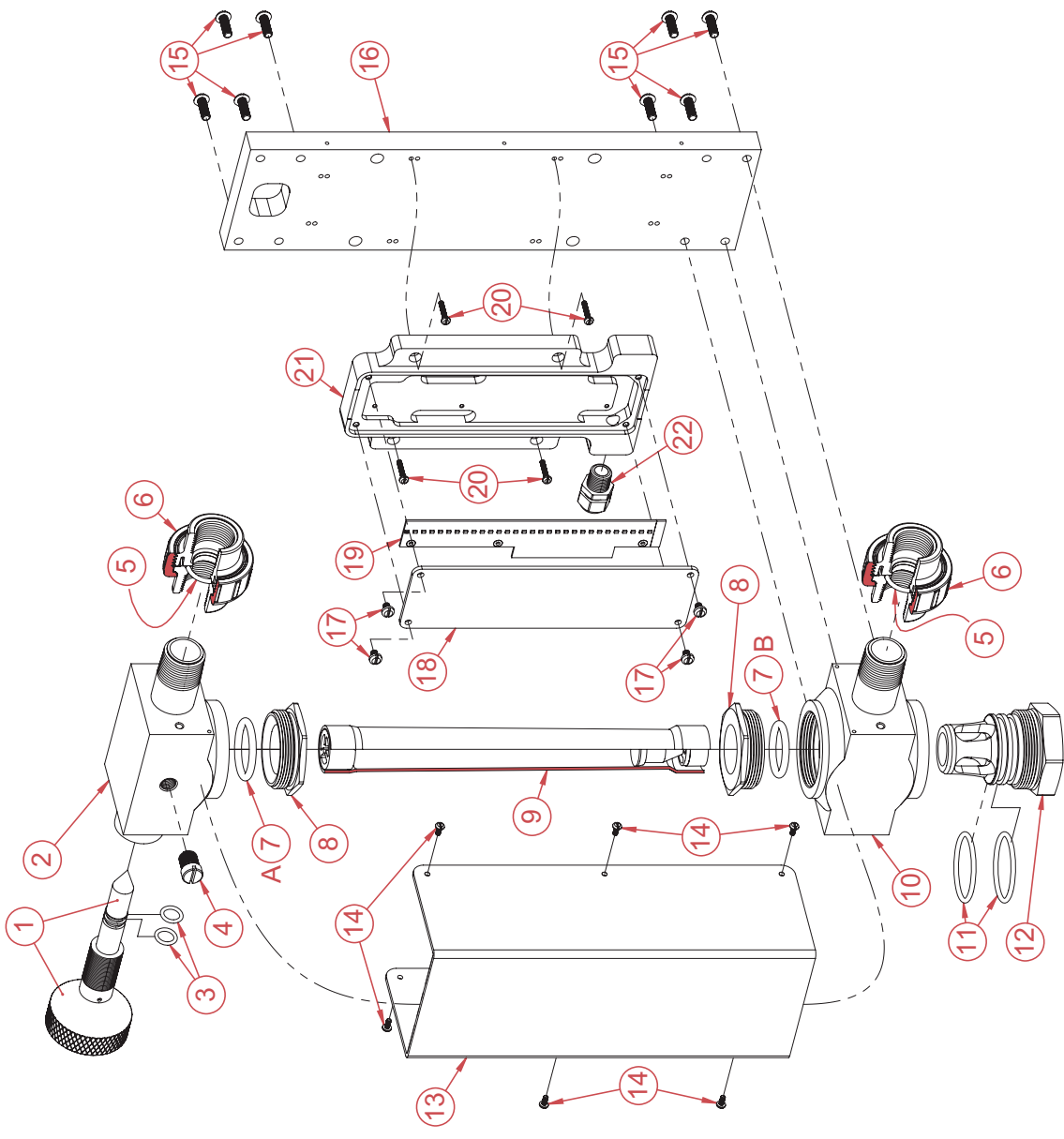

XXXX =
 1000
 2000
 3000



midpro
 INSTRUMENTS™
 Date: 2021-11-17-v1
BILL OF MATERIALS
 12" HIGH CAPACITY REMOTE METER,
 1,000-3,000 PPD (20-60 kg/h) Analog Output 4-20mA, EXP
 Dwg. No. RMH-XXXX-CL2-420MA, EXP

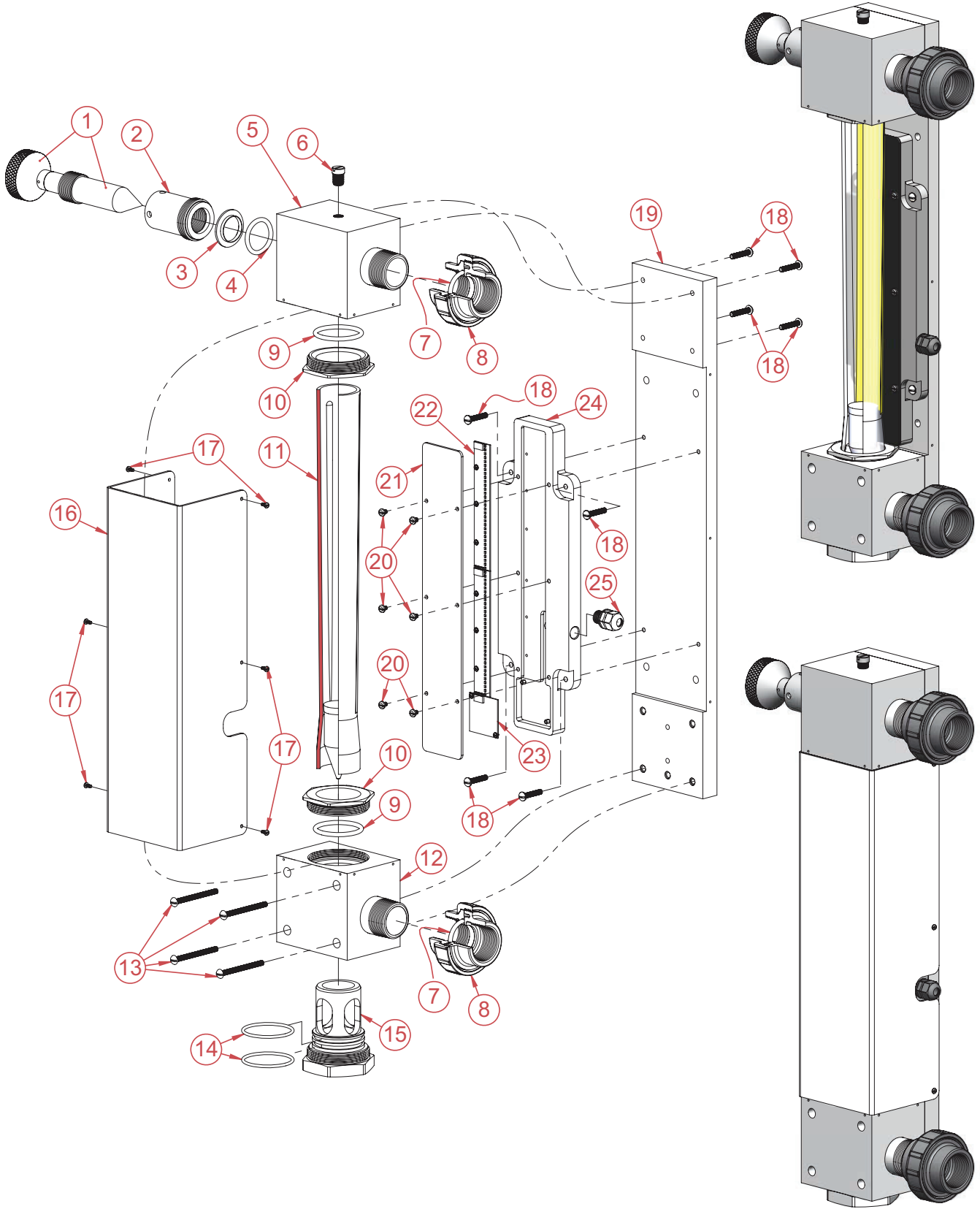

XXXXX =	4000
	6000
	8000
	10000



 Date: 2022-12-06-v1
BILL OF MATERIALS
 20" HIGH CAPACITY REMOTE METER,
 4,000-10,000 PPD (80-200 kg/hr) Analog Output 4-20mA
 Dwg. No. RMH-XXXXX-CL2-420MA, EXP

Item No.	Description	Quantity	Part No.
1	Rate Valve Stem & Knob	1	RVH-412-10000
2	Valve Bonnet	1	MBH-VB-10000
3	^{PM} Shaft Seal	1	RVH-852-SEAL
4	^{PM} O-Ring (for Rate Valve)	1	OH-VIT-324
5	Top Meter Block (Uses 1.5" PVC union)	1	MBH-UB2-10000
6	¼" NPT Plug	1	PLH-108-250
7	^{PM} O-Ring (for 1.5" PVC union)	2	OH-VIT-328
8	1.5" Union	2	U-4298
9	^{PM} O-Ring	2	OH-VIT-330
10	Meter Tube Hex Nut	2	MBH-THN-10000
11A	20" Meter Tube (4,000 PPD / 80 Kg/h) with Magnet Float	1	MTB-080KG-20-420MA
11B	20" Meter Tube (6,000 PPD / 120 Kg/h) with Magnet Float	1	MTB-120KG-20-420MA
11C	20" Meter Tube (8,000 PPD / 160 Kg/h) with Magnet Float	1	MTB-160KG-20-420MA
11D	20" Meter Tube (10,000 PPD / 200 Kg/h w/ Magnet Float	1	MTB-200KG-20-420MA
12	Bottom Meter Block (Uses 1.5" PVC Union)	1	MBH-LB3-10000
13	¼-20 x 3" Bolt	4	BTH-STA-279
14	^{PM} O-Ring	2	OH-VIT-229
15	Meter Inlet Plug	1	MIH-500-000
16	Meter Shield	1	MSU-20T-THN
17	Shield screw	6	#6-32 x 5/16"
18	¼-20 x 1 ¼" Bolt	4	BTH-STA-130
19	Meter Base	1	MBH-MB-10000-1
20	Screw	6	10-24 x ¼"
21	Circuit Board Cover	1	MPH-10000-CBC
22	Sensors Board	2	
23	Circuit Board	1	
24	Mounting Plate	1	MPH-10000-MP
25	Liquid Tight Fitting	1	BLT-199
-	O-Ring for Liquid Tight Fitting	1	OH-VIT-112
-	Float with magnet (4,000 PPD / 80 Kg/h)	1	MTB-080KG-20-420MA-FL
-	Float with magnet (6,000 PPD / 120 Kg/h)	1	MTB-120KG-20-420MA-FL
-	Float with magnet (8,000 PPD / 160 Kg/h)	1	MTB-160KG-20-420MA-FL
-	Float with magnet (10,000 PPD / 200 Kg/h)	1	MTB-200KG-20-420MA-FL
^{PM}	Part & Maintenance Kit	1	KTH-10000-MPS

XXXXX =	4000
	6000
	8000
	10000

	Date: 2022-12-06-v1
	BILL OF MATERIALS
<small>20" HIGH CAPACITY REMOTE METER, 4,000-10,000 PPD (80-200 kg/hr) Analog Output 4-20mA</small>	Dwg. No. RMH-XXXXX-CL2-420MA, BOM

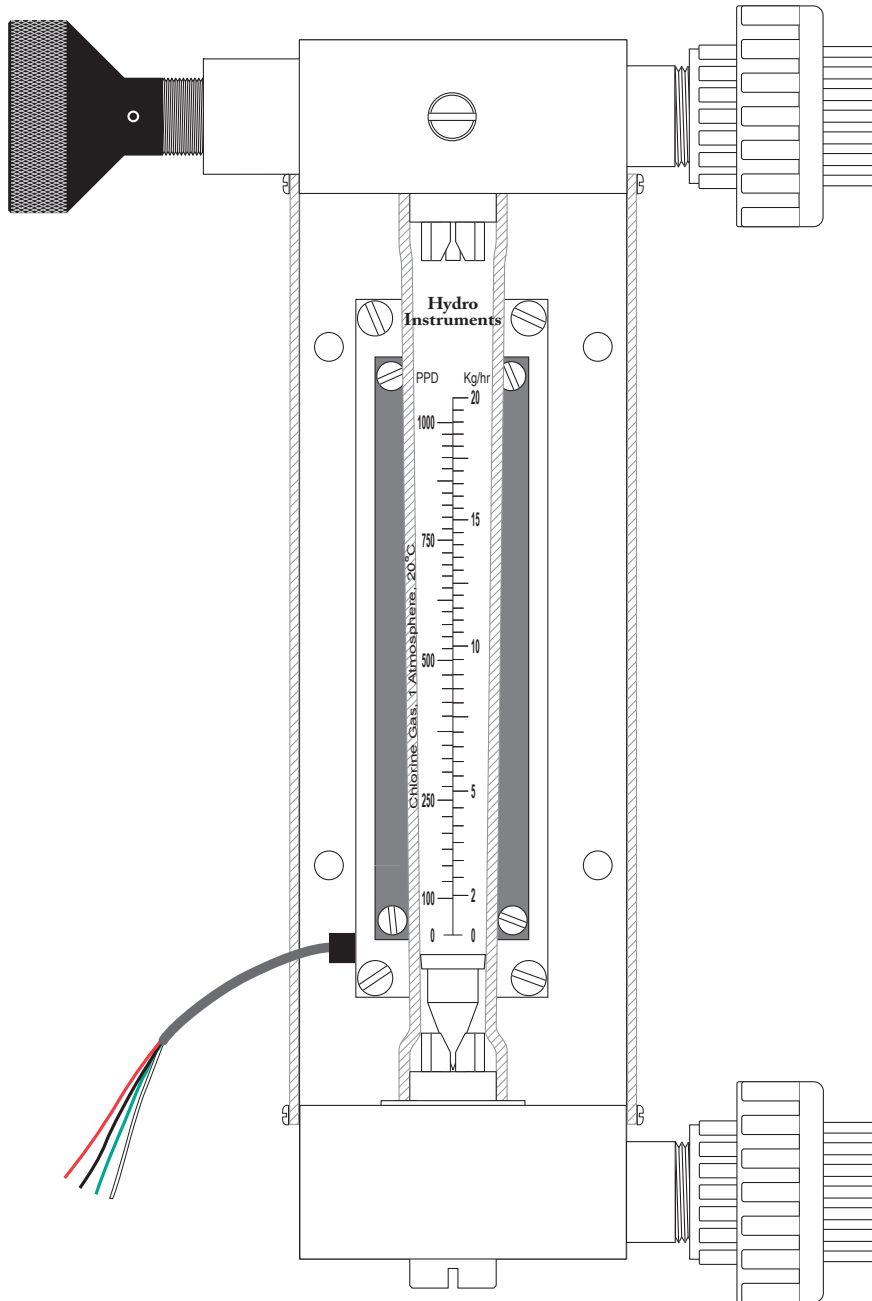
TITLE		DATE	
Remote Meter with 4-20mA Output		6/21/2013	
SCALE	MEASUREMENTS	DWG. NO.	
40%	Inches <hr style="width: 50%; margin: 0 auto;"/> Millimeters	Wiring Diagram	



Red	Black	Green	White
V+	V-	AO+	AO-