

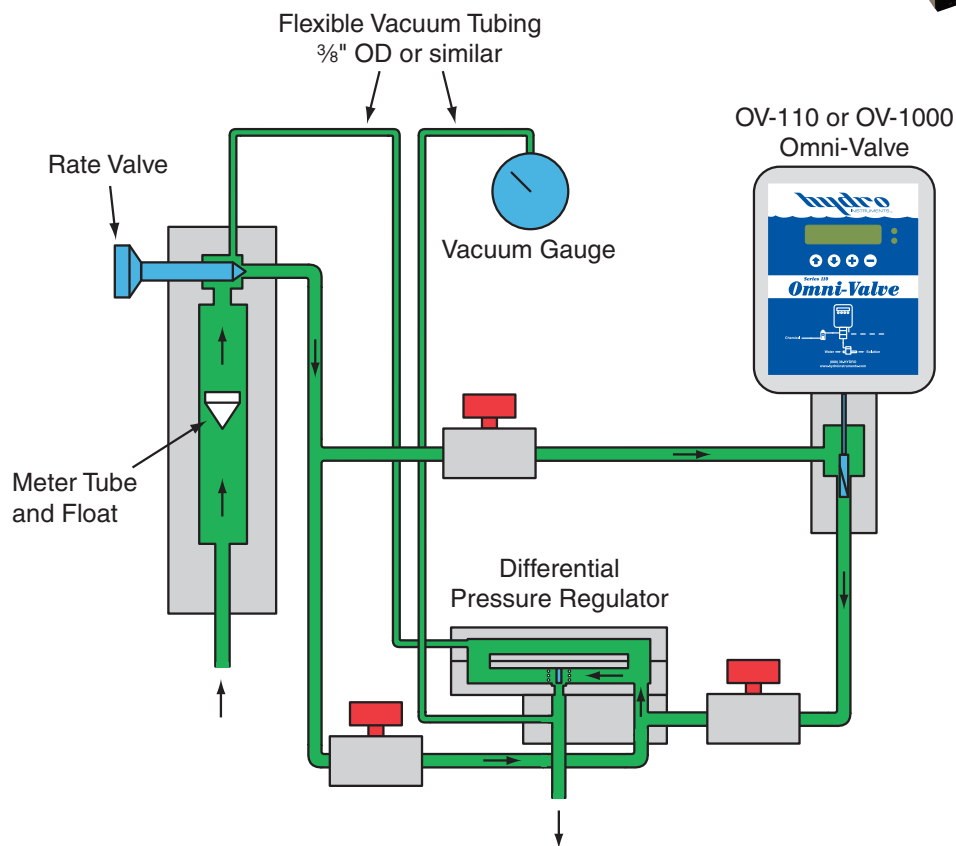

Floor Cabinets High Capacity Gas Chlorination Equipment

Hydro Instruments has been manufacturing highest quality gas chlorination equipment since 1978. Our gas chlorination equipment is manufactured using highest quality materials for both chemical resistance and physical durability.

Hydro Instruments floor cabinets provide a convenient and aesthetic free standing mounting for gas chlorination feed rate indication and control equipment. The floor cabinets are durable free standing fiberglass housings used to mount flow meters, control valves, vacuum gauges, vacuum switches, etc. Floor cabinets are available in a range of sizes and with a variety of options. Consult with your local sales representative for details.



Floor Cabinets

High Capacity Gas Chlorination Equipment

Floor Cabinets – General Specifications:

Floor Cabinet General

1. The free standing floor cabinet shall be constructed of corrosion resistant materials and be used to house the chlorine gas feed rate measurement and control equipment.
2. Operation of the manual and automatic control valves shall be fully accessible without the need to open the floor cabinet structure. Operation of the bypass ball valves shall also be accessible from the rear without the need for opening the cabinet housing.
3. Manual bypass using true union ball valves will be optionally included in the floor cabinet.

Series OV-110 or OV-1000 Omni-Valve *(NOTE: For more detailed specifications please refer to the Series OV-110/OV-1000.)*

1. The Omni-Valve shall be comprised of a microprocessor controller and automatic control valve, constructed together in one compact unit.
2. The microprocessor based automatic control valve shall adjust the gas feed rate based on one, two, or three electronic input signals or by means of any or all of four input relays.
3. The automatic control valve shall allow for the following standard, field selectable control modes: manual, (flow) proportional control, (residual/ORP) set-point control, (PID) Compound Loop control and Step-Feed Control.
4. Motion of the valve shall be achieved by means of a linear stepper motor with 1.25" (OV-110) or 2.25" (OV-1000) travel.
5. Motion control shall be achieved without the use of a feedback potentiometer.
6. To ensure accurate feed rates throughout the range of operation, the software shall incorporate a 10-point valve linearization calibration.

Differential Pressure Regulator *(NOTE: This equipment is optional.)*

The differential pressure regulator shall maintain a constant pressure differential across a variable or fixed orifice providing a steady flow rate regardless of variations in upstream or downstream pressure.

Flow Meter and Manual Rate Valve

Each Floor Cabinet will include at least one glass tube and float type flow meter and also a manual rate control valve.

Outlet Vacuum Gauge

Floor Cabinets shall be provided with one vacuum gauge with diaphragm protection that is connected to the outlet section in order to provide a visual indication of ejector vacuum level.

Inlet Vacuum Gauge

Floor Cabinets may optionally be provided with one vacuum gauge with diaphragm protection that is connected to the outlet section in order to provide a visual indication of floor cabinet inlet vacuum level.

Vacuum Switches

Floor Cabinets may optionally be provided with one or more vacuum switches that can be used to low alarm in the case of loss of system vacuum or high alarm in the case of loss or blockage of chemical supply.

